

WARDROBE ASSEMBLY INSTRUCTIONS

Please note: these instructions are generic for all of our cabinets and are not bespoke to your individual order.

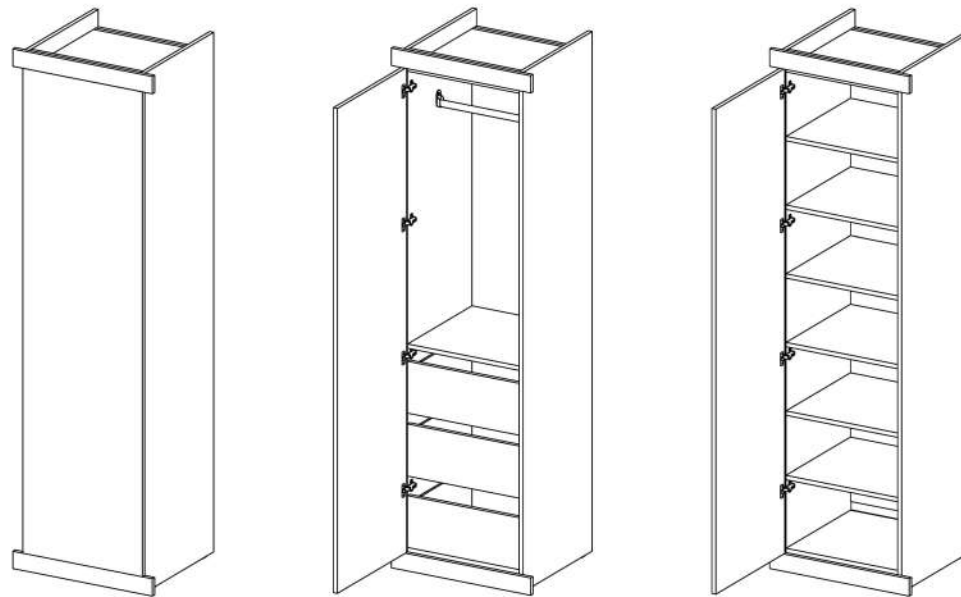

POINT YOUR SMARTPHONE
CAMERA HERE!



SOME ELEMENTS OF THE ASSEMBLY
MAY REQUIRE TWO PEOPLE



YOU MAY NEED:
SCREWDRIVER, CIRCULAR SAW, DRILL

PROBLEMS? A BIT STUCK? CALL US ON 0115 718 0322



ASSEMBLY ORDER

1. Cabinets

You'll assemble & level your cabinets first, putting them into the correct order

2. Side Scribes and/or End Panels (if required)

You'll then add your Side Scribes and/or End Panels, as required

3. Top & Bottom Plinths

Once side scribes are on, you'll fit your top and bottom plinths

PROBLEMS? A BIT STUCK? CALL US ON 0115 718 0322

ASSEMBLY INSTRUCTIONS

HARDWARE

PART



4 per cabinet

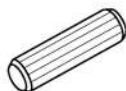

4 per cabinet



Bag of 30mm screws



Bag of 40mm screws



Bag of cam screws



Bag of 17mm screws

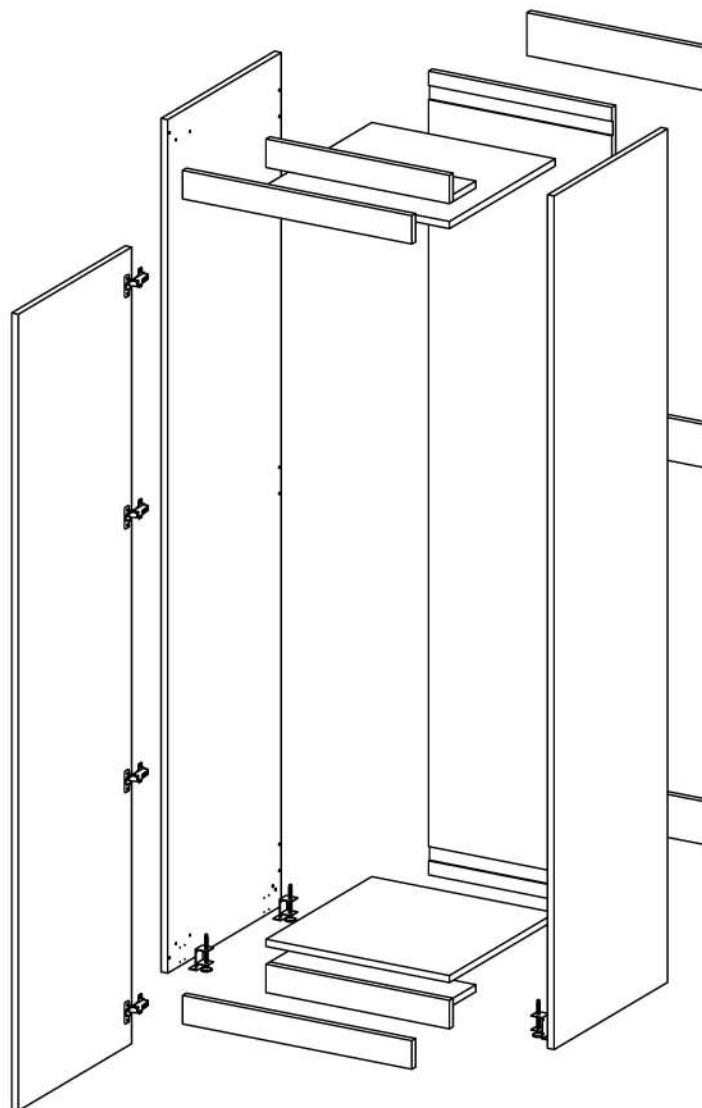

ASSEMBLY INSTRUCTIONS

STEP 1
Screw legs onto the side panel using 17mm screws

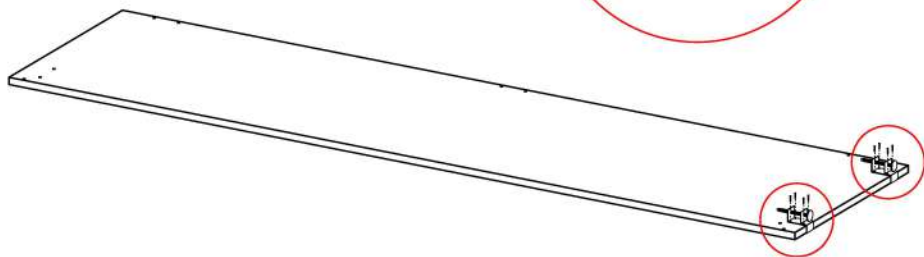
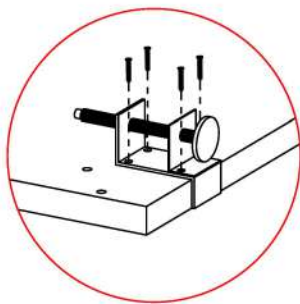

STEP 2
Push 8mm dowels into 8mm holes on side panel

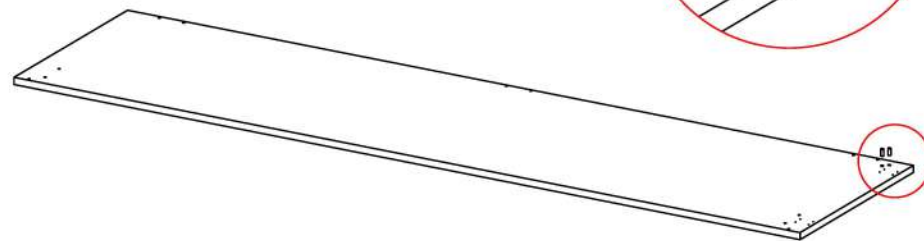
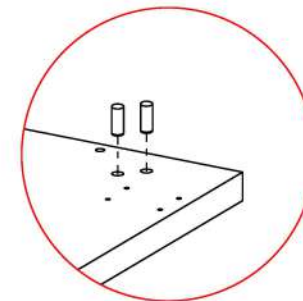

STEP 3
Screw cam screws into 12 holes shown

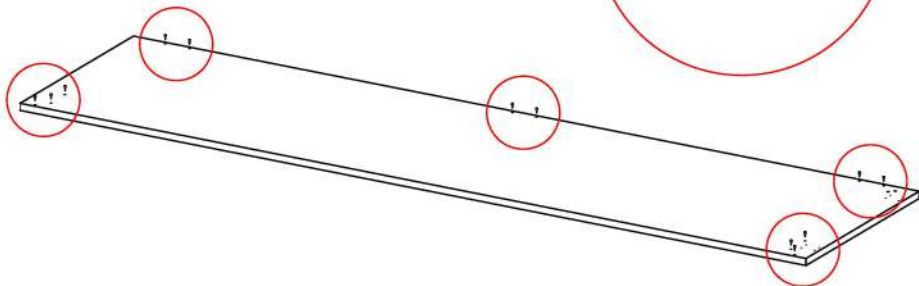
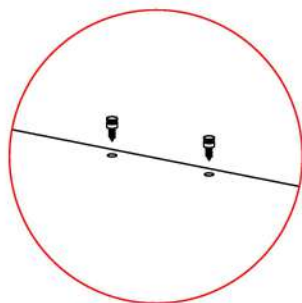

STEP 4
Repeat for other side panel

ASSEMBLY INSTRUCTIONS

STEP 5

With left side upright

Attach 2 x L-shaped braces to the front cam screws - use a screwdriver to tighten the cams



STEP 6

Attach 3 x flat rear baces into cam screws at the rear

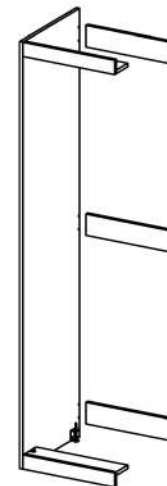

STEP 7

Attach right side to create the wardrobe frame

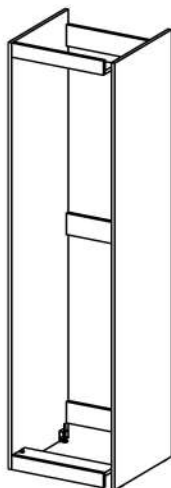

STEP 8

Fit the wardrobe back by locating the bottom onto the dowels and tipping upright against rear braces.

Check that you have the back panel the correct way up. The holes should align with the holes in the side panels

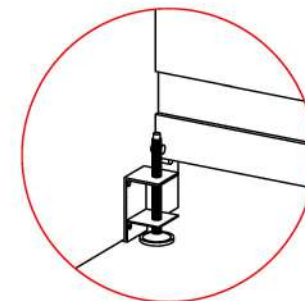
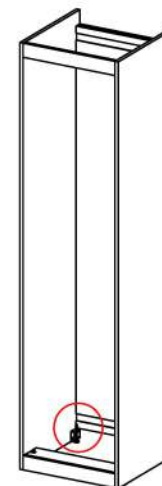

ASSEMBLY INSTRUCTIONS

STEP 9

Fix back into place with 2 x 30mm screws through the holes in top edge of the back

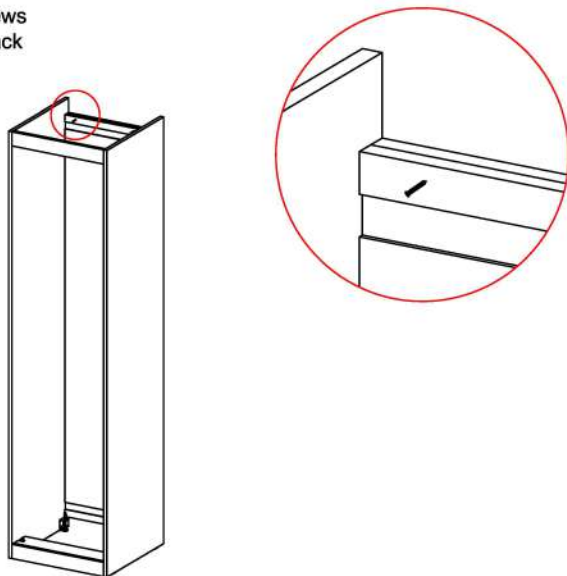

STEP 10

Raise the cabinet 25mm off the floor by extending the legs using a screwdriver

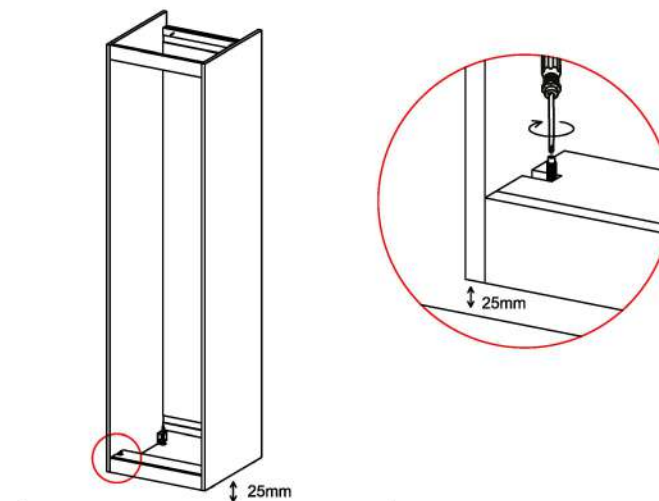

STEP 11

Assemble any additional cabinets and place next to each other in the correct order shown on your plan

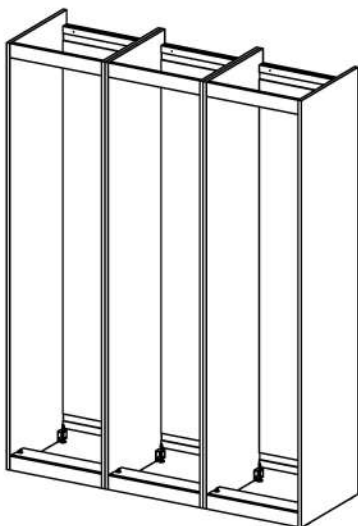

STEP 12

Ensure cabinets are in the right order and the correct placement to give you even side infills. Using a screwdriver to adjust the legs, level each cabinet before fixing each unit to the next using 6 x 30mm screws

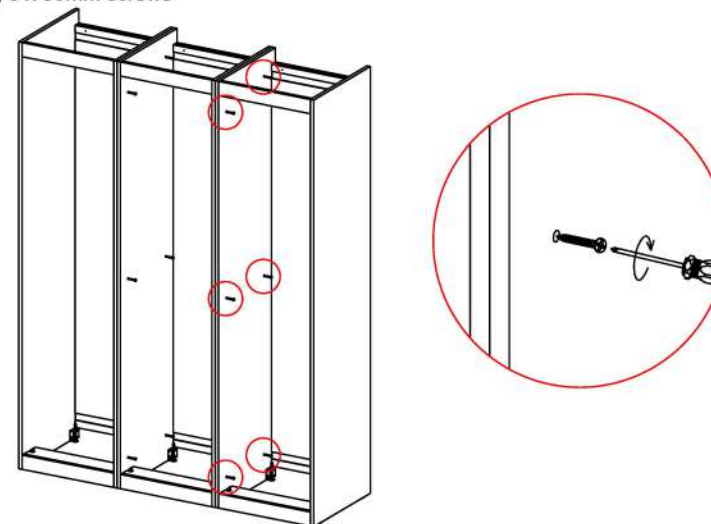

ASSEMBLY INSTRUCTIONS

STEP 13

Fix the cabinets to the wall with appropriate fixing method

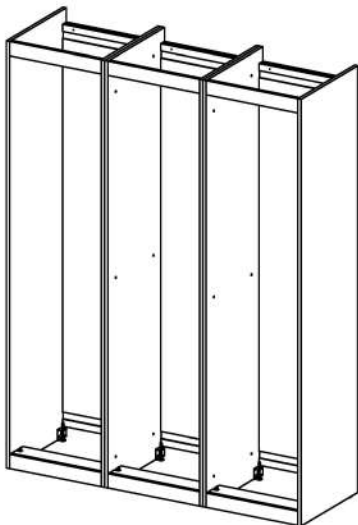

STEP 14

If you have scribe panels, you will need to fit them now

how to

FIT SCRIBE PANELS

TO OUR WARDROBES

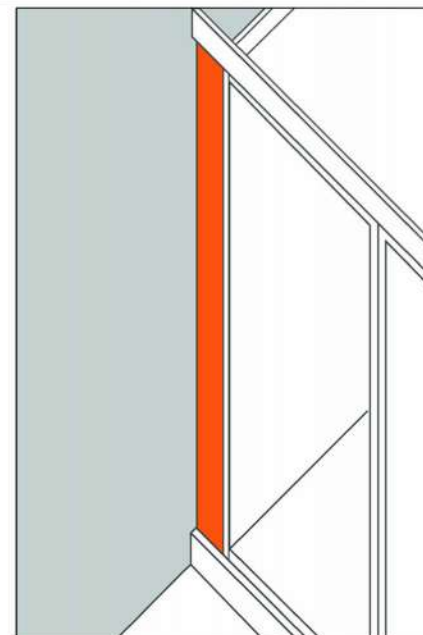

ASSEMBLY INSTRUCTIONS

1 Offer the 150mm side scribe up to the wall

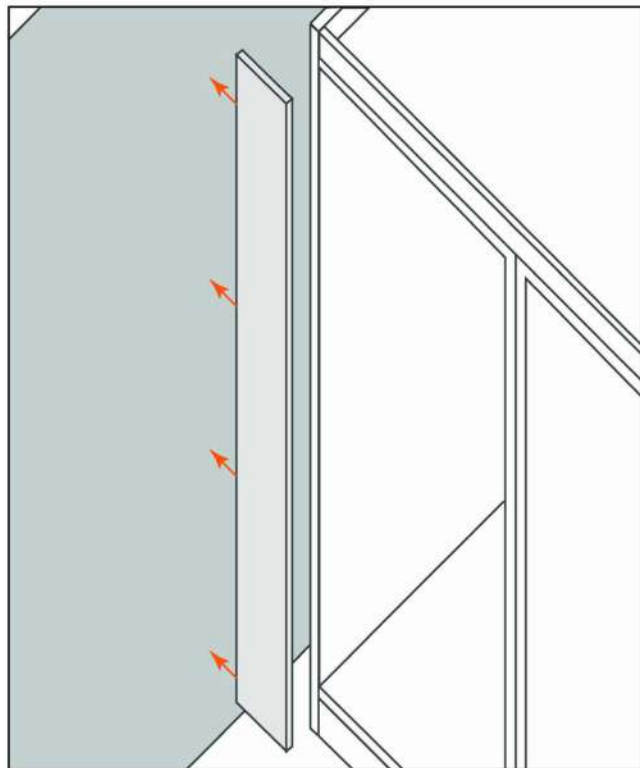

! The side scribe is fitted **BEFORE** the top plinth is fitted

2 Using a pencil, flat against the wall, mark a line down the length of the panel. – by keeping the pencil flat against the wall it will transfer any undulations in the wall onto the panel.

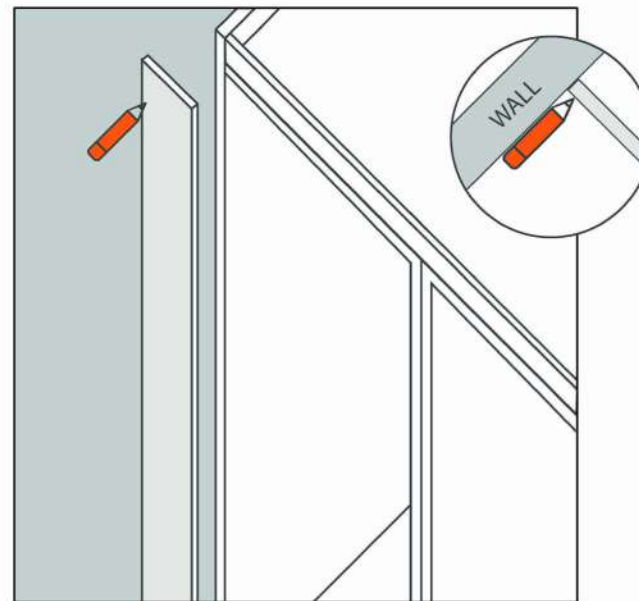

! If the wall is too far out of square the pencil may fall off the edge of the panel. If this is the case then use a pair of compasses or wrap tape around the shaft of the pencil to make it thicker.

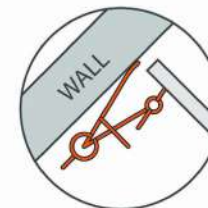

ASSEMBLY INSTRUCTIONS

3

3. Use a jigsaw or circular saw with a chipboard blade to cut to the line.

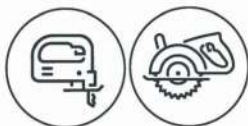

4

4. If you need to further refine this cut to get closer to the line then a handheld belt sander will help here.



5

5. Offer the panel back up to the wall to make sure that the line you have cut is correct.

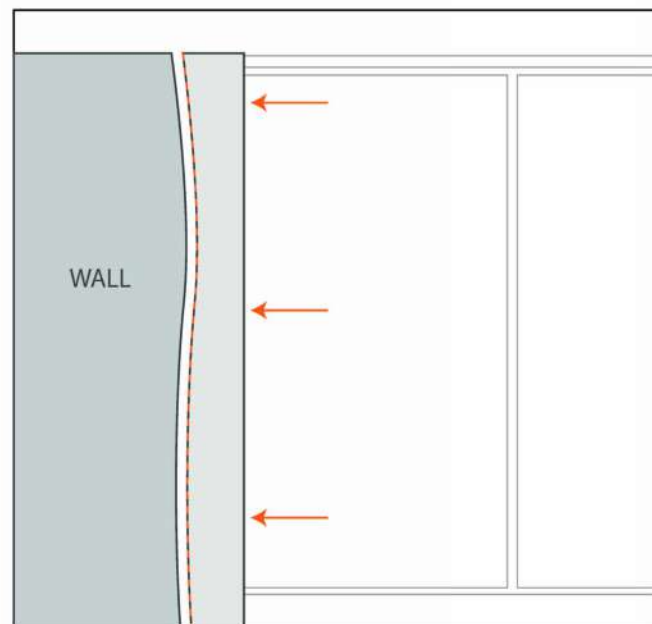

If the panel does not fit the shape of the wall
Start again on the same edge from step 1

If the panel does fit the shape of the wall
Move to step 6

ASSEMBLY INSTRUCTIONS

- 6** Measure the width at the top and the bottom of the gap between the wardrobe and wall and mark these onto the panel, from the already cut side.

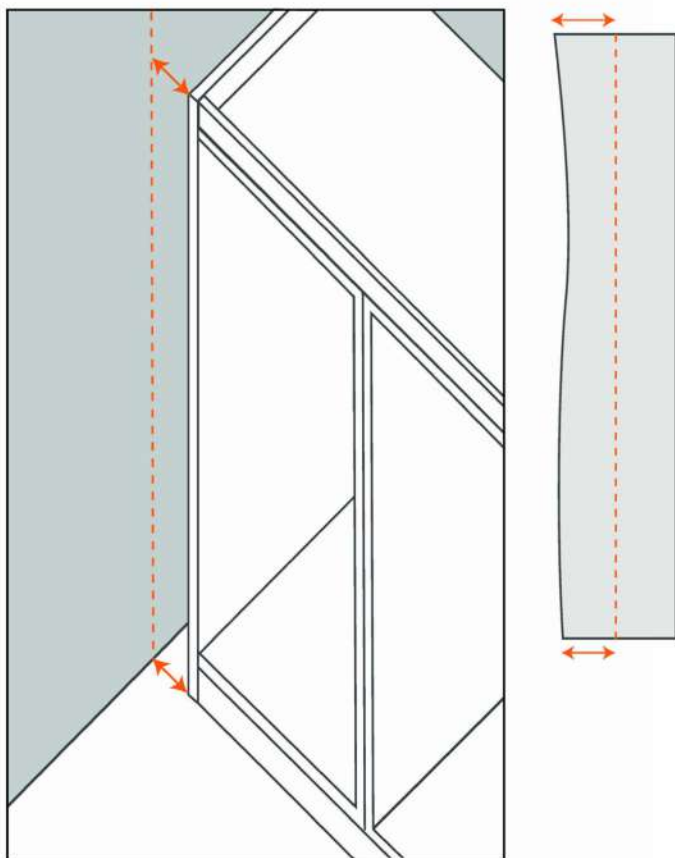

- 7** Cut the panel to the correct width as marked.

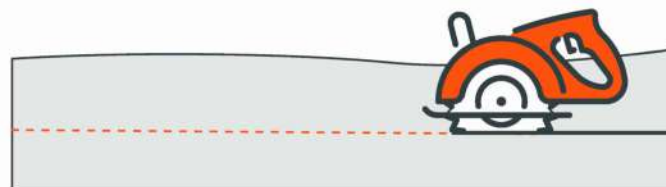

- 10** Using the provided 40mm screws, screw through the holes in the cabinet, into the side scribe panel

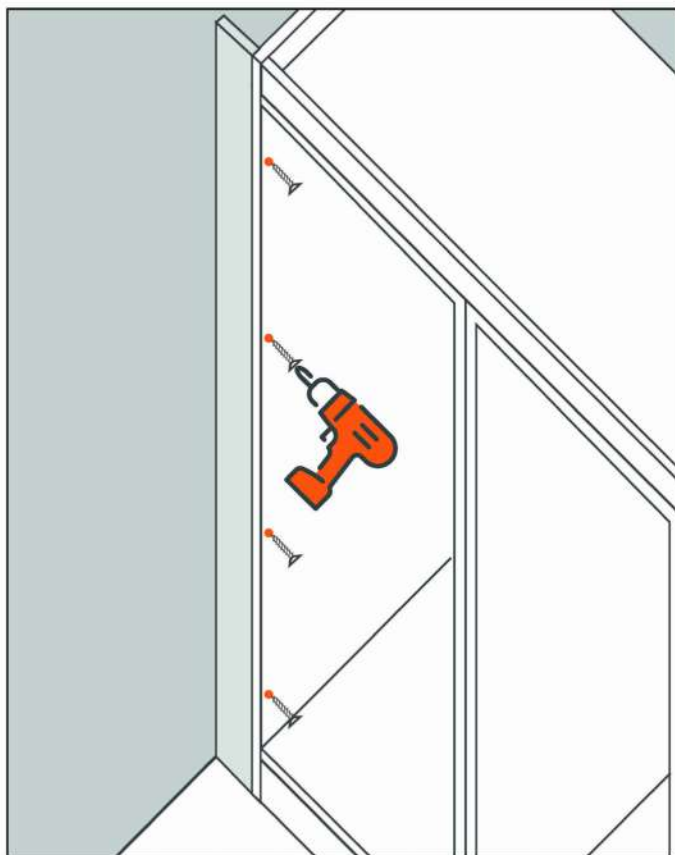

- 11** For the best finish we recommend using a colour matched silicone between the panel and the wall.

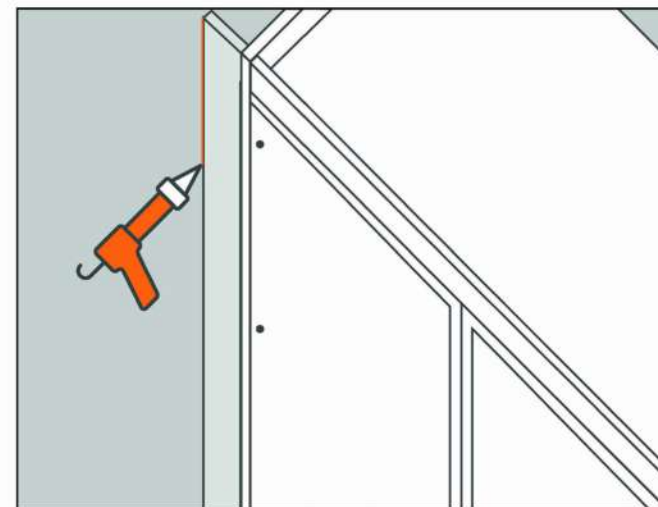

- !** This will help to cover any small chips from cutting as well as give you a secure fixing to the wall side.

ASSEMBLY INSTRUCTIONS

STEP 15

Clamp the bottom plinth to the L-shaped brace and screw the plinth to the brace from the inside using 30mm screws.

You may need to scribe the bottom plinth to the floor before attaching to the units

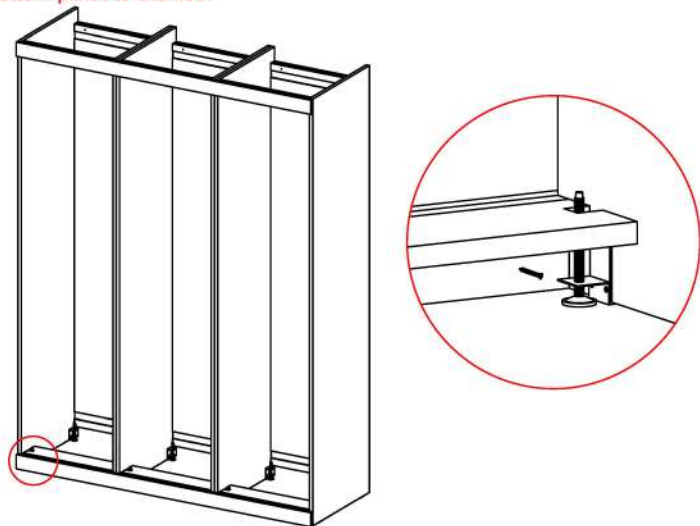

STEP 16

Repeat the process on the top plinth
(Note: Screw holes in the L-shaped brace)

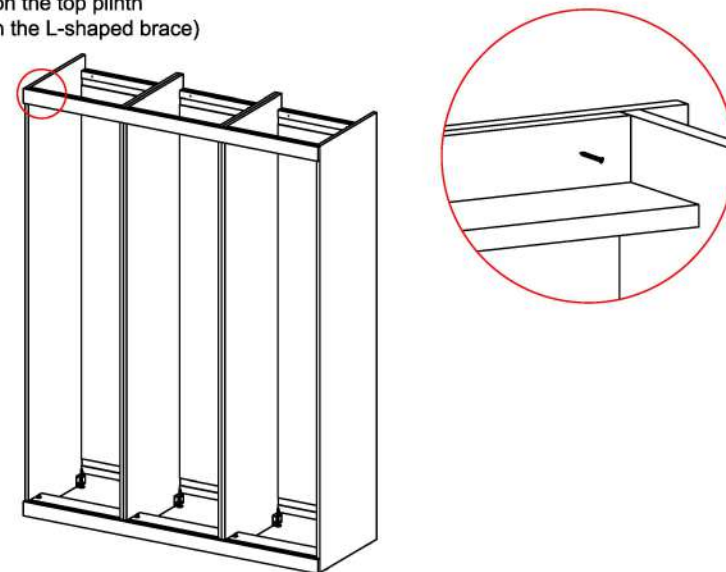

STEP 17

Slide bottom panel into the groove in the back panel and lay flat on the front brace (Note: Screw holes to the front)

Using 40mm screws, fix bottom panel into place

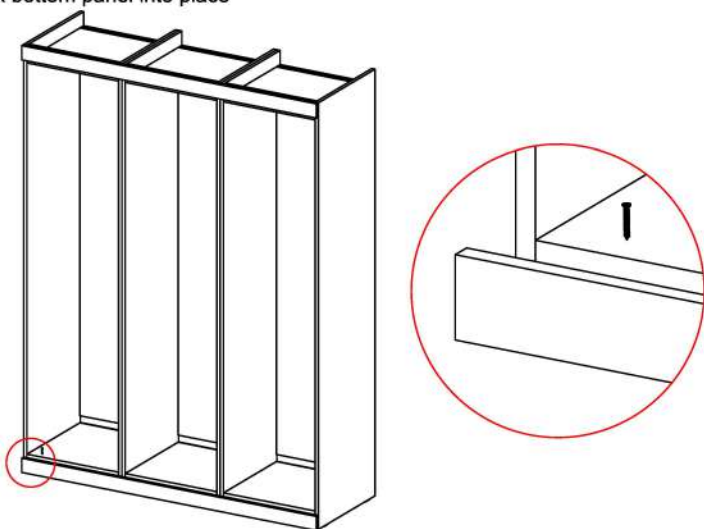

STEP 18

Repeat the process on the top panel.

You will need to scribe the top plinth before attaching it to the units

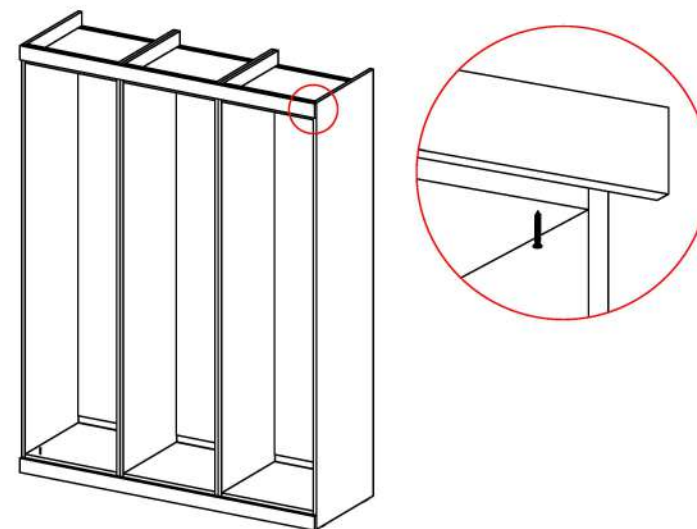

ASSEMBLY INSTRUCTIONS

STEP 19

Wardrobes are now built.
holes will be different for each internal configuration,
depending on options purchased

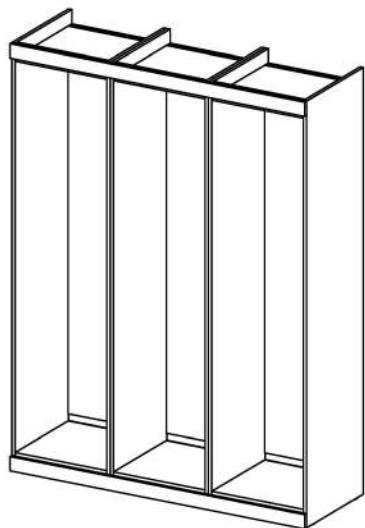

STEP 20

Single Hanging

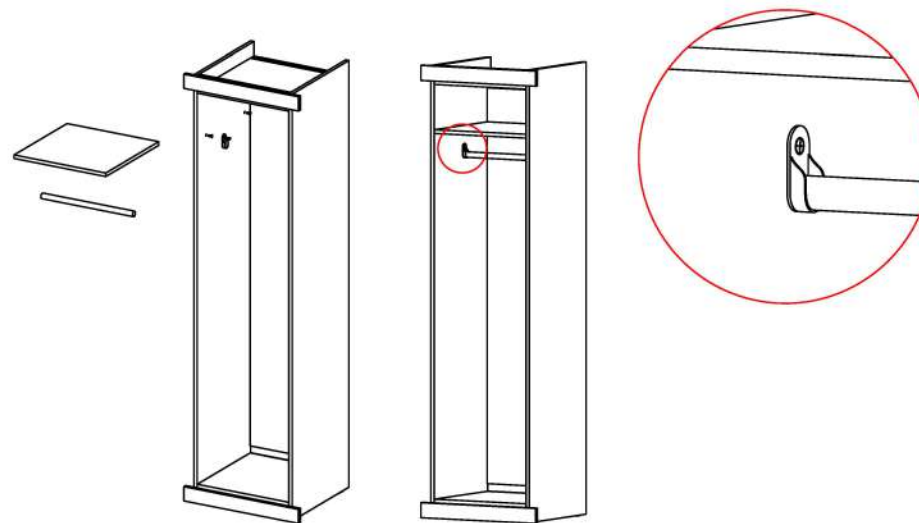

STEP 21

Double Hanging

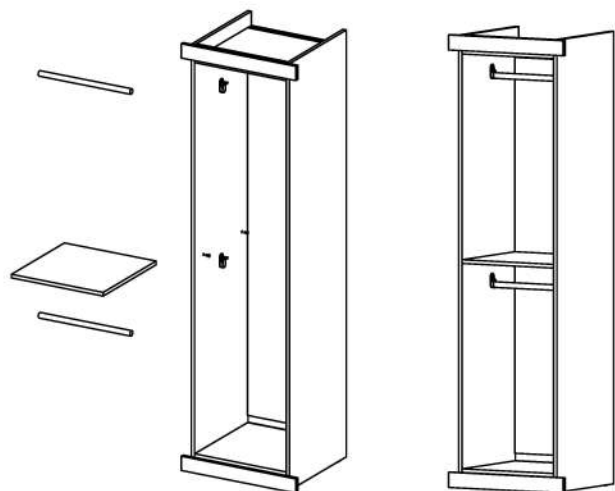

STEP 22

Full Shelves

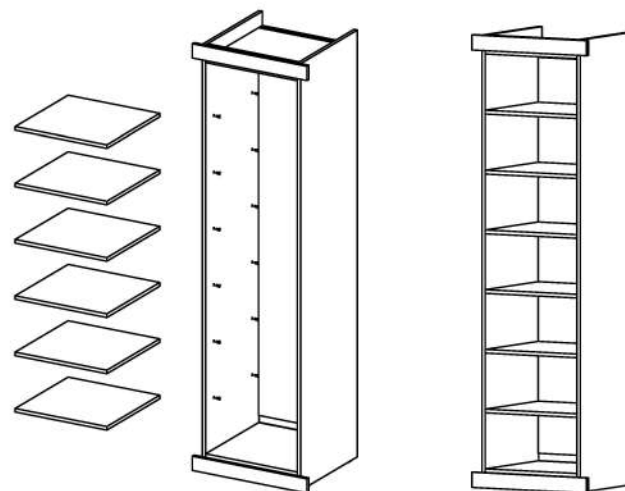

ASSEMBLY INSTRUCTIONS

STEP 23
Drawers below hanging

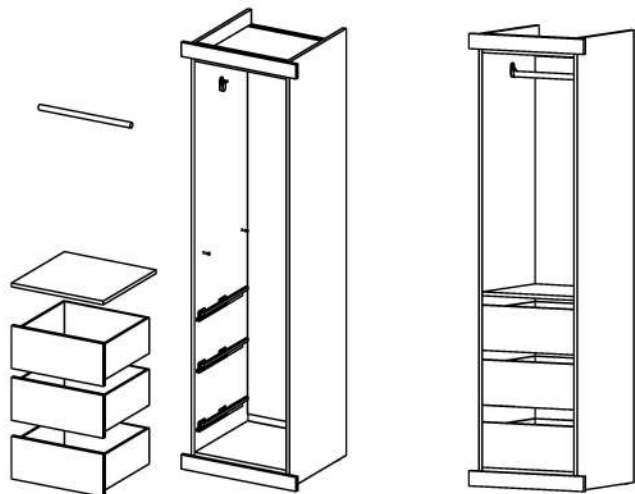

STEP 24
Screw the drawer runner to the cabinet using the 5mm diameter screws provided in the box with the drawers. Use holes 4, 6, 11 and 14

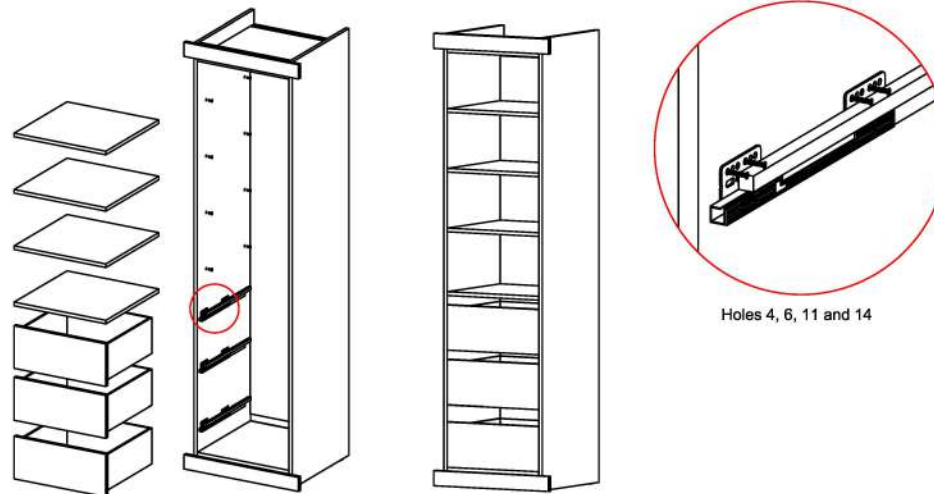

STEP 25
To fit the doors, screw the hinges onto the doors using 17mm screws

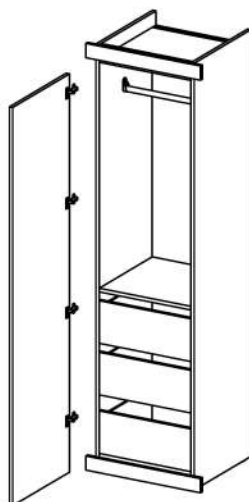

STEP 26
Mount the door by lifting it into place and lining up the screws with the hinge holes on the cabinet

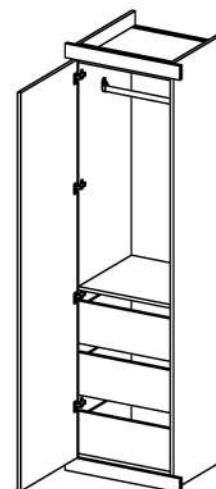

ASSEMBLY INSTRUCTIONS

STEP 27

Ensure that the mouting plates are fitting fully flush into the cabinet before driving the screws tight

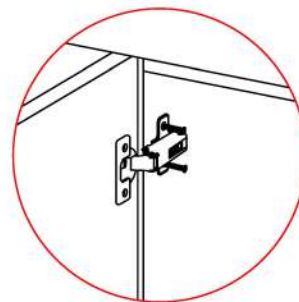
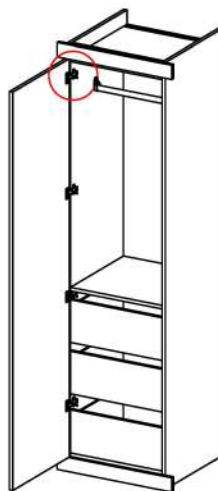

COMPLETE

